

VIEW A(1/10)

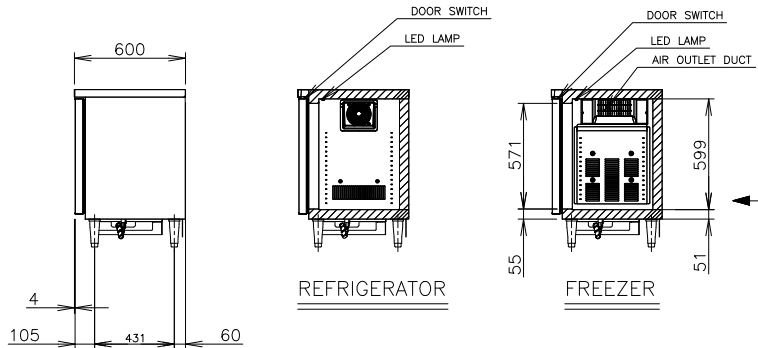

ITEM	Hoshizaki Undercounter Freezer/Refrigerator
MODEL	RFT-186MC-S
POWER SUPPLY	1 Phase 220-240V~50Hz Capacity 0.75kVA (3.50A)
AMPERAGE	Rated 2.7A
ELECTRIC CONSUMPTION	Motor 360W(Power Factor 77%) Heater 506W Refrigeration 425.6W Defrost 380W
HEAT REJECTION	826W
POWER CORD	Plug with Earth Wire
EFFECTIVE CAPACITY	384L (Refrigerator:258L) (Freezer:126L)
Energy consumption	*kWh/day (Based on ISO 22041-2019)
OUTSIDE DIMENSIONS	1800mm (W) x 600mm (D) x 850(-880) mm (H)
INSIDE DIMENSIONS	Refrigerator 897mm (W) x 436mm (D) x 599mm (H) Freezer 462mm (W) x 436mm (D) x 599mm (H)
EXTERIOR	Stainless Steel, Galvanized Steel (Rear / Bottom) ABS Plastic (Top & Bottom on Door)
INTERIOR	Stainless Steel, Stainless Pack(Door)
INSULATION	Polyurethane Foam
INSULATION FOAM BLOWING AGENT	Cyclopentane
REFRIGERATION SYSTEM	Forced Air Circulation
DEFROST SYSTEM	Glass Tube Heater
COMPRESSOR	Hermetic
CONDENSER	Fin and Tube type, Air-cooled
EVAPORATOR	Fin and Tube Type
REFRIGERANT	R290
TEMPERATURE CONTROL	Microprocessor (Digital Temp Indication) Adjustable from Refrigerator -6 to 12°C Freezer -25 to -7°C
DEFROST CONTROL	Microprocessor controlled
ELECTRIC CIRCUIT PROTECTION	Earth Wire, Circuit Breaker
COMPRESSOR PROTECTION	Motor Protector
LEG	Plastic Adjustable 150 to 180mm
SHELF	6pcs.
WEIGHT	Net:109kg (Gross: Approx.130kg)
PACKAGE	Carton 1865mm (W) x 680mm (D) x 845mm (H)
ACCESSORIES	EVAPORATING PAN
OPERATING CONDITIONS	Ambient Temperature: 5-38°C Voltage Range: Rated Voltage±6%

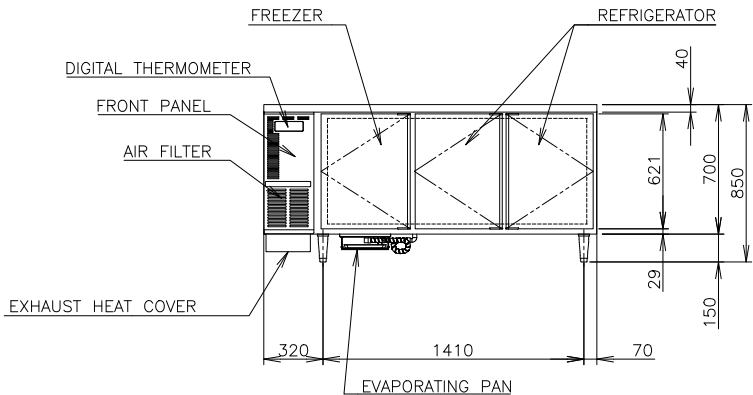
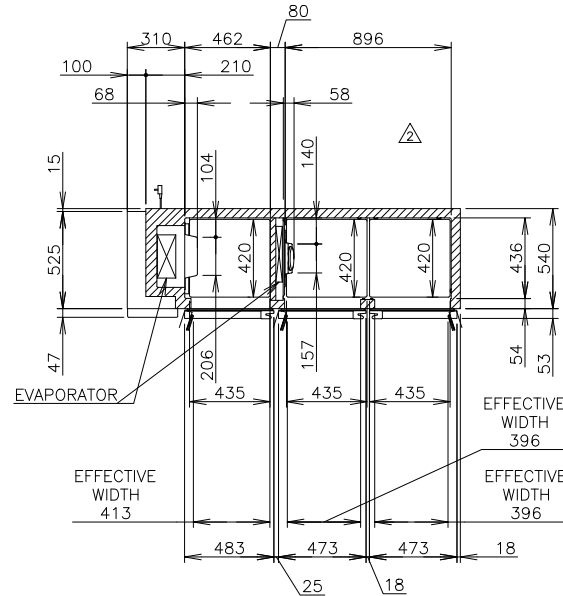
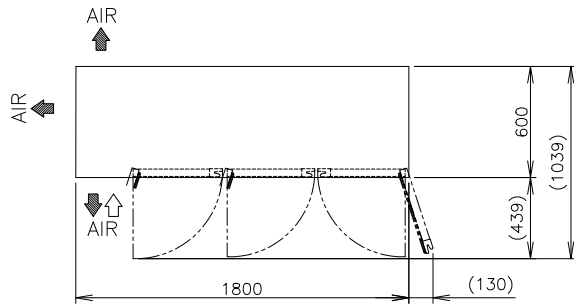
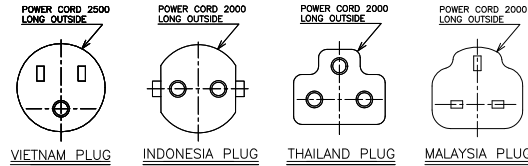

\*We reserve the right to make changes in specifications and design without prior notice.

1. Install the product properly in accordance with the instructions on location, electrical connections stated in the instruction manual provided. Allow 10mm extra space at the installation site to meet any installation requirements (additional spacing is also required for proper air flow, pipe connections).

2. Product code: T426-V100(VIETNAM)  
T426-V200(INDONESIA)  
T426-V300(THAILAND)  
T426-V400(MALAYSIA)